



Member of SCHAKO Group

**NOVENCO**

Building & Industry

**Novax**

**Tunnel fans**



# Product facts

## Product

Novenco tunnel fans are produced with either round or rectangular outer dimensions. Both types are made in unidirectional (AUC and AUR) and reversible (ARC and ARR) versions with capacities up to 3000 N of thrust.

## Application

The fans have been developed for ventilation of tunnels with aggressive atmospheres such as road traffic and train tunnels. They provide an effective way of handling polluted air and smoke from fires. The fans are in fact part of many concepts for fire fighting.

## Sizes and versions

Novenco tunnel fans are manufactured in four rectangular sizes and nine round sizes.

Rotor diameters range from Ø500 to Ø800 mm for rectangular versions and from Ø630 to Ø1600 mm for round versions.

## Construction

The inner fan casing consists of a circular fan tube fitted with either rectangular or round flanges. Silencers are mounted on each flange.

A wire guard is mounted on the inlet side and a deflector is mounted on the outlet side. The deflector allows for deflection of air in any desired direction.

Reversible tunnel fans are delivered with deflectors mounted on both sides.

Fans are as standard delivered with suspension brackets for direct mounting to ceilings.

## Motors

The motors are either 3x400 V, 50 Hz or 3x690 V, 50 Hz.

**Motor protection:** Min. IP55 in accordance with IEC 34-5

**Insulation class:** F or H depending on temperature protection

**Motor flanges:** B14 in accordance with IEC 34-7, alternatively B5

## Electric isolation

The tunnel fans can be delivered with terminal boxes, or with an electric isolating switch.

## The Novax rotor

The impeller consists of two hub discs with cavities, in which the blades are mounted in preset positions.

## Silencers

The silencers are placed on both sides of the fan casing. Silencers are fitted with inlet and outlet cones designed for minimum pressure loss.

## Materials

**Blades:** Aluminium alloy

**Hub:** Sendzimir galvanised steel plate which can be epoxy coated

**Casing and motor suspension:** Welded steel plate, hot-dip galvanised or stainless steel

**Silencers:** Sendzimir galvanised steel plate or stainless steel

**Inside tube for silencers:** Perforated galvanised plate or stainless steel

**Sound attenuating material:** Fire-proof and moisture resistant

**Cones:** Galvanised or stainless steel

**Wire guard:** Stainless steel

**Deflector:** Galvanised steel and aluminium or stainless steel

**Suspension brackets:** Hot-galvanised 3 mm steel sheet

## Classifications

The fans meet requirements for operation in unheated, low corrosive environments according to DS/EN ISO 12944-2, corrosion category C3.

The operating temperature range is as standard -20 to +40 °C.

Max. temperature range is from -40 to +120 °C.

Fans used for hot smoke removal can operate at 200 to 400 °C for 1 to 2 hours.

Balancing of the rotor unit is in accordance with VDI 2060, ISO 1940, 1-1986 class Q 6.3.

# Contents



Description	4
Dimensions and technical specifications	7

## Important

This document is provided 'as is'. Novenco reserves the right to changes without further notice due to continuous product development.

The fan is designed for continuous operation. The following kinds of operation may cause fatigue break in the impeller and endanger people.

- Operation in stall area
- Operation with pulsating counter pressure – called pump mode
- Operation with repeated starting and stopping

If in doubt, Novenco should be contacted to assess the suitability of the fan.

Copyright (c) 2007 - 2015, Novenco A/S.  
All rights are reserved.

## Patents and trademarks

Novenco<sup>®</sup>, ZerAx<sup>®</sup>, 诺文科 and 诺克 are registered trademarks of Novenco A/S.

The ZerAx<sup>®</sup> manufacturing processes, technologies and designs are patented by Novenco A/S. Pending US patents include no. 13/498,741; 13/498,785; 13/498,733; 14/234,654 and 14/234,735. Granted US patents include no. D665895S, D683840S, D692119S, D704323S and D712023S.

Other trademarks appearing in this document are the property of their respective owners.

## Quality and environment

Novenco is certified in accordance with ISO 9001 and 14001.



# Description

Novenco tunnel fans type Novax build on Novenco's ventilation system knowledge and pose an energy saving, silent and efficient alternative compared to conventional duct systems.

All tunnel fans use Novenco's unique impeller design.

## Jet principle

Systems using Novenco tunnel fans employ the jet principle to push air through the tunnel from intake to exhaust. The air is moved by impulses injected by a sufficient number of tunnel fans mounted in the ceiling.

Tunnel fans function by sucking a small part of air in and expelling it with high speed. The ambient air is thereby set in motion.

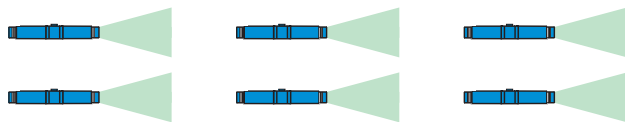

Sample distribution of fans

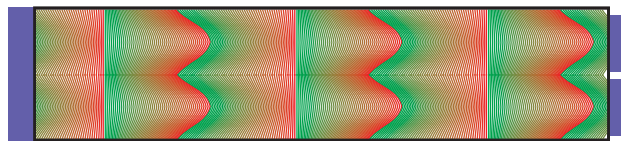

Movement profile of air controlled by tunnel fans

## Tunnel ventilation systems

The systems consist in principle of the following components.

- Air supply – either naturally through the entrance or mechanically through a shaft, or through a combination of the two
- Air exhaust – either naturally through the other entrance or by mechanical exhaust
- A number of tunnel fans
- Detection system for exhaust gases like CO and NOX
- A control system based on data from the detection system

If a system is used in connection with fires, the following must also be included.

- Fire detection system
- Alarm system for evacuation of the tunnel and for alerting the fire service

## Pollution ventilation

The need for ventilation is calculated based on the physical tunnel dimensions, the expected usage level and distribution of heavy and light vehicles, as well as controlling regulations.

The polluted air is mixed and pushed to the extraction sites by the tunnel fans.

## Smoke control

In case of fire the system is used for keeping one part of the tunnel free from smoke and to assist fire fighting personnel in pinpointing the fire. The required air velocity to stop the smoke is calculated based on a worst case scenario as well as the architectural tunnel layout.

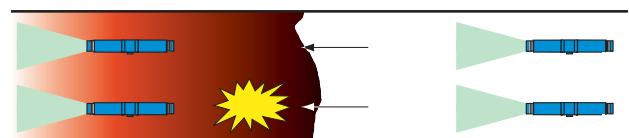

Principle of smoke control

Once the fire is put out, the system is used for clearing the tunnel of smoke. This enables rescuers to quickly search the area for casualties.



The necessary air volume and air speed are calculated from the authorities' requirements for smoke extraction.

## Calculation of longitudinal tunnel ventilation systems

This kind of tunnel ventilation systems are generally designed based on thrust in Newton ( $\text{Pa}/\text{m}^2$ ). The total thrust is the sum of the separate thrusts generated by each of the active jet fans. The total thrust must be large enough to overcome all resistance in the tunnel.

Thrust calculations are based on the following.

- Thrust of the jet fans
- Influence of the positions of the jet fans
- Resistance of the empty tunnel
- Inflow and outflow losses of the tunnel
- Effect of traffic
- Effect of wind
- Pressure drop over the source of the fire
- Required velocity of the airflow in the tunnel

### Thrust of the jet fans

The jet fans must supply the required thrust. In addition to the jet fan system the traffic and the wind can in some cases also make a positive contribution to the total thrust available.

### Actual effective thrust in the tunnel tube

Both the air velocity in the tunnel tube and the position of the jet fans reduce the actual effective thrust of a jet fan.

### Positional efficiency

The jet fans create a high speed jet flow along the tunnel interior. The losses caused by friction are allowed for in the positional efficiency of the jet fans.

The output efficiency mainly depends on the distance of the jet fan from the side wall and ceiling.

Installing jet fans after each other in the longitudinal direction requires care in order for the fans not to affect each other. The velocity of the throw at the next row of fans should not be higher than the average velocity of the airflow in the tunnel.

By using deflectors on the outlet of the jet fans the influence of positional efficiency can be reduced.

More information on calculation of longitudinal tunnel ventilation systems is available on [www.novenco.nl](http://www.novenco.nl). Novenco's Dutch office is our centre of excellence for tunnel ventilation.

## Product description

### Fan types

The tunnel fans are manufactured in both round (AUR/ARR) and space saving rectangular (AUC/ARC) types. Both types are made in either unidirectional or reversible designs.

The rotors range in diameter from Ø630 to Ø1600 mm for fans with round cross-sections and from Ø500 to Ø800 mm for the rectangular versions.

### Fan casing

The fan casing is a welded steel construction in 3 mm hot-dip galvanised sheet steel. Alternatively, the casing can also be made in stainless steel.

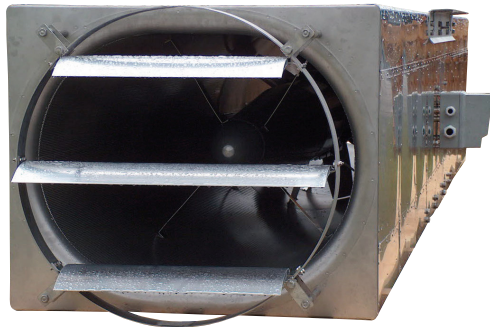

*Deflector on an ARC tunnel fan*

### Motors

These are either 3x400 V, 50 Hz or 3x690 V, 50 Hz both with direct start. The motor protection is IP 55 in accordance with IEC 34-5. Insulation is class F or H.

### Safety switches

All fan types can be delivered with safety switches mounted or with terminal boxes.

### Installation

The fans have brackets for mounting in ceiling.

### Temperature operating range

The range is as standard -20 to +40 °C.

Fans used for fire fighting can operate between 200 - 400 °C for 1 - 2 hours. Please note that the given performance at 400 ° cannot be delivered by all fan sizes.

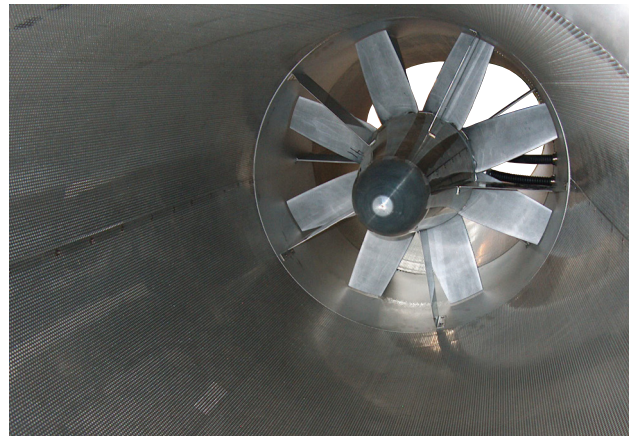

*Inside an AUC tunnel fan*

# Dimensions and technical specifications



## Dimensions

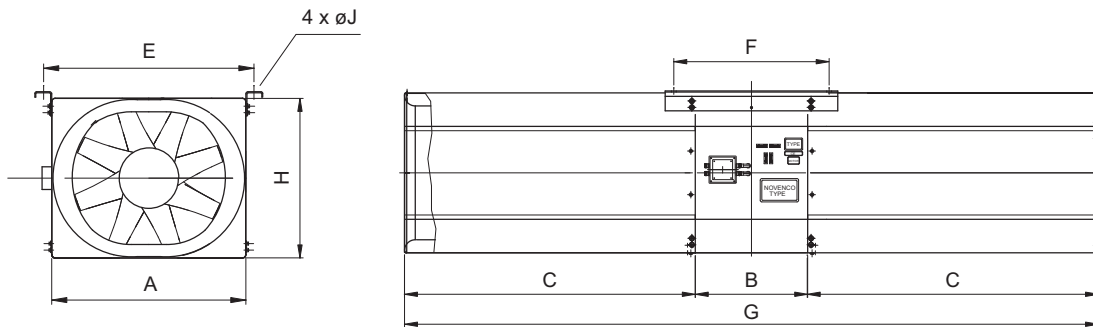

	A [mm]	C [mm]	B [mm]	F [mm]	E [mm]	ØJ [mm]	H [mm]	G [mm]	Total weight <sup>1</sup> [kg]
630/280-8	820	1350	520	720	895	24	670	3220	350
710/280-8	900	1350	520	720	975	24	750	3220	430
800/280-8	990	1350	520	720	1065	24	840	3220	480

AUC-ARC sizes 630 - 800 – unidirectional and reversible

1. Excludes weight of motor.

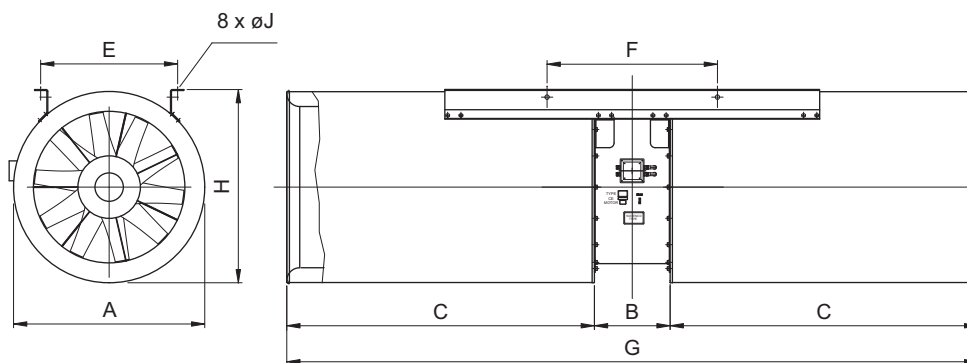

	ØA [mm]	C [mm]	B [mm]	F [mm]	E [mm]	ØJ [mm]	H [mm]	G [mm]	Total weight <sup>1</sup> [kg]
630/280-8	840	1375	400	900	600	24	850	3150	220
710/280-8	920	1500	400	900	660	24	930	3400	280
800/280-8	1010	1625	400	900	760	24	1020	3650	360
900/403-6	1115	1050	850	925	760	24	1118	2950	460
1000/403-6	1215	1200	850	925	760	24	1218	3250	510
1120/403-6	1338	1250	850	925	800	24	1339	3350	560

AUR-ARR sizes 630 - 1120 – unidirectional and reversible

1. Excludes weight of motor.

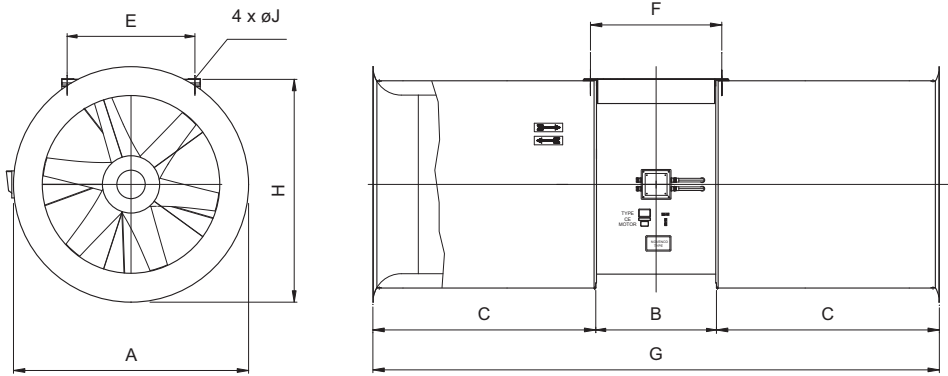

	ØA [mm]	B [mm]	C [mm]	E [mm]	F [mm]	G [mm]	H [mm]	ØJ [mm]	Total weight <sup>1</sup> [kg]
1250/403-6	1650	850	1570	900	925	3990	1560	24	610
1250/578-10	1650	850	1570	900	925	3990	1560	24	630
1400/403-6	1800	1120	1720	1000	1220	4560	1710	24	760
1400/578-10	1800	1120	1720	1000	1220	4560	1710	24	780
1600/578-10	2000	1120	1920	1150	1220	4960	1910	24	840

AUR-ARR sizes 1250 - 1600 – unidirectional and reversible

1. Excludes weight of motor.





## Specifications

	Thrust meas.	Motor rating	Thrust efficiency	Volume flow	Air speed	Shaft power	Rotor RPM	Sound power <sup>1</sup>
Fan type	[N]	[kW]	[N/kW]	[m <sup>3</sup> /s]	[m/s]	[kW]	[RPM]	[dB(A)]
500/160-4	109	2.2	53	4.39	22.2	2.1	2900	87
630/280-8	290	7.5	39.8	8.91	28.58	7.0	2900	90
	382	12	35.6	10.23	32.81	10.5	2900	92
	470	15	32.2	11.34	36.36	14.5	2940	93
	542 <sup>2</sup>	18.5	30.1	12.18	39.06	18.0	2940	94
710/280-8	305	7.5	43.0	10.30	26.01	7.1	2900	91
	417	12	39.3	12.03	30.38	10.5	2900	93
	527	15	36.3	13.52	34.16	14.5	2940	94
	627	18.5	33.9	14.75	37.26	18.0	2940	95
	768	26	29.6	16.34	41.26	25.4	2940	97
800/280-8 <sup>3</sup>	681	18.5	37.2	17.33	34.47	18.0	2940	98
	850	26	33.8	19.35	38.50	25.1	2940	99

Fan performance data for AUC at varying thrust levels

	Thrust meas.	Motor rating	Thrust efficiency	Volume flow	Air speed	Shaft power	Rotor RPM	Sound power <sup>1</sup>
Fan type	[N]	[kW]	[N/kW]	[m <sup>3</sup> /s]	[m/s]	[kW]	[RPM]	[dB(A)]
500/160-4	105	2.2	60	4.29	21.8	1.8	2900	80
630/280-8	272	7.5	37.8	8.61	27.63	7.2	2900	93
	356	12	33.0	9.85	31.61	10.8	2900	94
	452	15	30.5	11.10	35.62	14.8	2940	96
	490 <sup>2</sup>	18.5	26.9	11.56	37.09	18.2	2940	97
710/280-8	318	7.5	42.4	10.28	25.89	7.5	2915	95
	388	12	35.3	11.59	29.28	11.0	2900	96
	492	15	34.2	13.06	32.98	14.4	2940	97
	560 <sup>2</sup>	18.5	31.5	13.57	34.27	17.8	2940	99
	663 <sup>2</sup>	26	26.5	15.15	38.28	25.0	2940	100
800/280-8 <sup>3</sup>	625	18.5	34.7	16.10	32.20	18.0	2940	101
	742	26	29.6	18.10	36.00	25.1	2940	102

Fan performance data for ARC at varying thrust levels

Fan type	Thrust meas.	Motor rating	Thrust efficiency	Volume flow	Air speed	Shaft power	Rotor RPM	Sound power <sup>1</sup>	
								1D	2D
	[N]	[kW]	[N/kW]	[m <sup>3</sup> /s]	[m/s]	[kW]	[RPM]	[dB(A)]	[dB(A)]
630/280-8	290	7.5	39.8	8.91	28.58	7.3	2900	96	92
	382	12	35.6	10.23	32.81	10.75	2900	98	94
	470	15	32.2	11.34	36.36	14.6	2940	99	95
	542 <sup>2</sup>	18.5	30.1	12.18	39.06	18	2940	100	96
710/280-8	417	12	39.3	12.03	30.38	10.6	2900	99	95
	527	15	36.3	13.52	34.16	14.5	2940	100	96
	627 <sup>2</sup>	18.5	33.9	14.75	37.26	18.5	2940	101	97
800/280-8 <sup>3</sup>	681	18.5	37.2	17.33	34.47	18.3	2940	103	99

Fan performance data for AUR at varying thrust levels

Fan type	Thrust meas. [N]	Motor rating [kW]	Thrust efficiency [N/kW]	Volume flow [m <sup>3</sup> /s]	Air speed [m/s]	Shaft power [kW]	Rotor RPM [RPM]	Sound power <sup>1</sup>	
								1D [dB(A)]	2D [dB(A)]
900/403-6	348	7.5	47.0	13.72	21.57	7.4	1450	90	87
	426	10	43.5	15.19	23.88	9.8	1450	91	88
	563	15	40.2	17.44	27.42	14	1470	93	90
1000/403-6	530	11	49.1	18.82	23.96	10.8	1470	92	89
	652	15	45.0	20.87	26.58	14.5		93	90
	761	18.5	42.0	22.54	28.70	18.1		94	91
	849	22	39.7	23.81	30.32	21.4		95	92
1120/403-6	755	15	52.4	25.15	25.53	14.4	1470	95	92
	870	18.5	49.4	27.00	27.41	17.6		95	92
	993	22	46.4	28.8	29.23	21.4		96	93
	1206	30	41.7	31.79	32.26	28.9		97	94
1250/403-6	1076	22	49.2	33.52	27.31	21.9	1470	98	95
	1267	30	44.9	36.36	29.63	28.2		99	96
	1495 <sup>2</sup>	37	41.3	39.49	32.18	36.2		100	97
1250/578-10	2138	75	29.5	47.24	38.49	72.4	1470	104	100
1400/403-6	1110	22	52.9	38.12	24.76	21	1470	100	97
	1388	30	48.4	42.63	27.69	28.7		102	99
	1614 <sup>2</sup>	37	45.0	45.96	29.86	35.9		102	99
1400/578-10	2434	75	33.6	56.45	36.67	72.5	1470	105	102
	2766	90	31.6	60.17	39.09	87.5		106	103
1600/578-10	2063	55	38.8	59.39	29.54	53.1	1470	106	103
	2667	75	36.8	67.52	33.58	72.5		107	104
	3002	90	35.0	71.64	35.63	85.7		107	104

Fan performance data for AUR at varying thrust levels (fortsat)

Fan type	Thrust meas. [N]	Motor rating [kW]	Thrust efficiency [N/kW]	Volume flow [m <sup>3</sup> /s]	Air speed [m/s]	Shaft power [kW]	Rotor RPM [RPM]	Sound power <sup>1</sup>	
								1D [dB(A)]	2D [dB(A)]
630/280-8	272	7.5	37.8	8.61	27.63	7.2	2900	98	93
	356	12	33.0	9.85	31.61	10.8	2900	98	94
	452	15	30.5	11.10	35.62	14.8	2940	101	97
	490	18.5	26.9	11.56	37.09	18.2	2940	104	100
710/280-8	388	12	35.3	11.59	29.28	11.0	2900	99	95
	492	15	34.2	13.06	32.98	14.4	2940	101	97
	573 <sup>2</sup>	18.5	32.2	14.09	35.59	17.8	2940	102	98
	663 <sup>2</sup>	26	26.5	15.15	38.28	25.0	2940	105	101
800/280-8 <sup>3</sup>	625	18.5	34.7	16.58	32.98	18.0	2940	105	101
	740	26	29.5	18.04	35.89	25.1		107	103
900/403-6	343	7.5	48.3	14.14	22.23	7.1	1450	92	89
	417	10	42.5	15.59	24.50	9.8	1470	93	90
	525	15	36.0	17.49	27.50	14.6	1470	95	92
1000/403-6	507	11	48.3	19.10	24.33	10.5	1470	95	92
	615	15	42.1	21.04	26.79	14.6		96	93
	695	18.5	38.4	22.36	28.48	18.1		97	94
	749	22	36.9	23.22	29.57	20.3		98	95

Fan performance data for ARR at varying thrust levels



Fan type	Thrust meas. [N]	Motor rating [kW]	Thrust efficiency [N/kW]	Volume flow [m <sup>3</sup> /s]	Air speed [m/s]	Shaft power [kW]	Rotor RPM [RPM]	Sound power <sup>1</sup>	
								1D [dB(A)]	2D [dB(A)]
1120/403-6	713	15	48.5	25.38	25.76	14.7	1470	100	97
	805	18.5	44.7	26.98	27.37	18.0		100	97
	869	22	41.0	28.01	28.43	21.2		101	98
	1004	30	35.1	30.11	30.56	28.6		103	100
1250/403-6	1030	22	48.6	34.04	27.74	21.2	1470	103	100
	1198	30	42.2	36.71	29.91	28.4		104	101
1250/578-10	1731	75	23.9	44.13	35.96	72.4	1470	107	103
1400/403-6	1105	22	52.6	39.68	25.78	21.0	1470	103	99
	1381	30	48.1	44.37	28.82	28.7		105	101
	1543 <sup>2</sup>	37	43.0	46.90	30.47	35.9		105	101
1400/578-10	2236	75	30.8	56.45	36.67	72.5	1470	108	104
	2438	90	27.9	58.94	38.29	87.5		109	105
1600/578-10	2052	55	38.6	61.81	30.74	53.1	1470	109	105
	2653	75	36.6	70.28	34.95	72.5		110	106
	2870	90	33.5	73.10	36.36	85.7		110	106

Fan performance data for ARR at varying thrust levels (fortsat)

1. Sound data is without deflector and wire protection guard.
2. Motor is unavailable for 400 °C at this motor rating and size.
3. Fan is unsuitable for 400 °C at these RPMs.

Motor data depends on the chosen motor make and are available on request from Novenco.



Novenco develops and manufactures ventilation systems that are marketed worldwide through subsidiaries and agents.

The company was founded in Denmark 1947 and has become one of the world-leading suppliers.

Novenco symbolises quality and environmentally responsible operation and is certified according to ISO 9001 and ISO 14001.

The company headquarters are located in Naestved, Denmark.

Novenco, ZerAx, 诺文科 and 诺克 are registered trademarks of Novenco A/S.

Read more about Novenco on the internet.